

The Function Of The Clem Engine

Axel G. Wörner

clemerator@yahoo.de

The first newspaper article about the Clem Engine was published on 2. June 1972. It has been more than 40 years and not one working prototype has been developed since.

Because of the simplicity und great power of this engine, it could change our dependence for oil, gas and electricity and therefore could be a great threat to our current wealth structure. I believe that this is why the people who control this world are trying to prevent this technology to get public. And what is the best way to prevent something like the Clem Engine to be reinvented again?

NO information at all or misinformation!

The function of the Clem engine is always associated with the so called Truncated Conical Drag Pump. The patent for this pump was issued October 10, 1972 under the patent # US3697190

The first newspaper article about the Clem Engine was published on June 2, 1972. This was more than **4 months** before the patent of the pump was issued.

I belief that Richard Clem must have invented and build the car a long time before the newspaper article was published. For this reason alone I do not belief that Richard Clem even knew about this so called Truncated Conical Drag Pump and the function of his Clem engine has nothing to do with this pump patent.

With this in mind I wonder how Richard Clem than came up with the idea of his engine. Having experience in fixing and building things led most people to improve the things they are working on. Richard Clem must have been a man with great technical skills who knew how to build things. I assume that Richard Clem was trying to improve something he worked on. The question is, "on what project did he work which let him to the invention of his engine"?

Now, let's assume that not everything about the Clem engine we can find in the WWW is posted there to get us on the wrong track.

If we take all the drawings and pictures we find in the WWW which are related to the Clem engine and ignore those which are based on the Truncated Conical Drag Pump, than it leaves us only with one picture which was supposedly published by Clem's daughter. This picture of the engine was supposedly used in the brochure which Clem used to find financial support by the 15 car manufactures, who all turned him down.

Here is the picture of this motor:

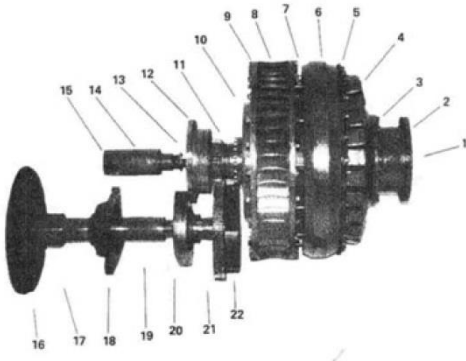

Because this picture resembles nothing I have ever seen, I just assume it really could be a picture of the engine.

What do we know for sure about the Clem engine?

The following information we can take from the June 2, 1972 published newspaper article:

- it used eight gallons (about 30 liters) of vegetable oil
- it runs at a temperature of about 300°F or about 140°C
- it uses a 12 volt battery, which Clem said "is used only to start the engine. Once started you can throw the battery away
- its main components are a seven stage pump and a "converter".
- The pump, as he described it, is used to move the oil, under pressure, from a storage area to the converter from where the energy is converted into enough power to turn the motor, move the oil back to the storage area and power the pump, which in turn continues the cycle.
- One hint as to the contents of the converter is "it acts like a turbine but isn't a turbine" in the normal sense of the word.

Based on that information we know that:

- The engine must be a sort of hydraulic engine
- the "converter" acts like a turbine
- the pump is used to move the oil to the converter

Considering the picture and the information's we have from the newspaper article we can pinpoint on which project Richard Clem worked on when he invented his engine.

My personal belief is that he worked on an improvement of a Hydraulic Ram Pump

What is a Hydraulic Ram Pump and how does it work?

Here is what we can read about it in Wikipedia.

A **hydraulic ram**, or **hydram**, is a [cyclic water pump](#) powered by [hydropower](#). It takes in water at one "[hydraulic head](#)" (pressure) and flow rate, and outputs water at a higher hydraulic head and lower flow rate. The device uses the [water hammer](#) effect to develop pressure that allows a portion of the input water that powers the [pump](#) to be lifted to a point higher than where the water originally started. The hydraulic ram is sometimes used in remote areas, where there is both a source of [low-head hydropower](#) and a need for pumping water to a destination higher in elevation than the source. In this situation, the ram is often useful, since it requires no outside source of [power](#) other than the [kinetic energy](#) of flowing water.

Sequence of operation[[edit](#)]

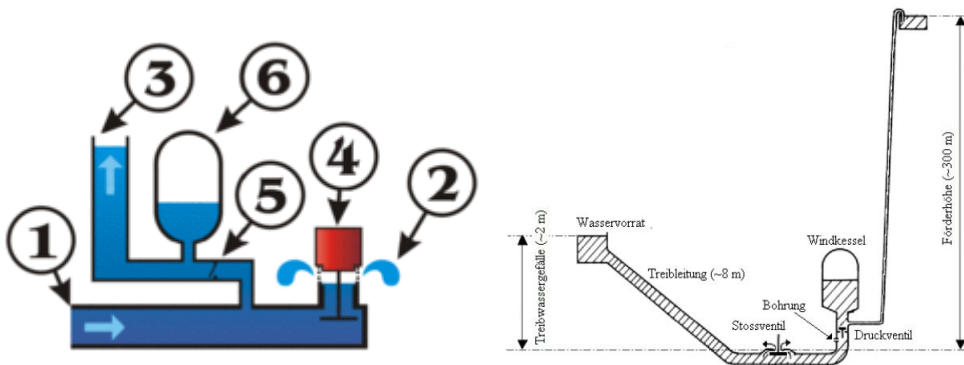

Figure 2: Basic components of a hydraulic ram:

1. Inlet – drive pipe
2. Free flow at waste valve
3. Outlet – delivery pipe
4. Waste valve
5. Delivery [check valve](#)
6. Pressure vessel

A simplified hydraulic ram is shown in Figure 2. Initially, the waste valve [4] is open, and the delivery valve [5] is closed. The water in the drive pipe [1] starts to flow under the force of [gravity](#) and picks up speed and [kinetic energy](#) until the increasing [drag](#) force closes the waste valve. The [momentum](#) of the water flow in the supply pipe against the now closed waste valve causes a [water hammer](#) that raises the pressure in the pump, opens the delivery valve [5], and forces some water to flow into the delivery pipe [3]. Because this water is being forced uphill through the delivery pipe farther than it is falling downhill from the source, the flow slows; when the flow reverses, the delivery check valve closes. Meanwhile, the water hammer from the closing of the waste valve also produces a pressure pulse which propagates back up the supply pipe to the source where it converts to a suction pulse that propagates back down the pipe. This suction pulse pulls the waste valve back open and allows the process to begin again.

A pressure vessel [6] containing air cushions the hydraulic pressure shock when the waste valve closes, and it also improves the pumping efficiency by allowing a more constant flow through the delivery pipe. Although, in theory, the pump could work without it, the efficiency would drop drastically and the pump would be subject to extraordinary stresses that could shorten its life considerably.

Drive Pipe (1)

Now let's assume that Richard Clem had the intent to exchange the long drive pipe (1) of the hydraulic ram pump with a centrifugal pump.

Here is a picture of a centrifugal pump.

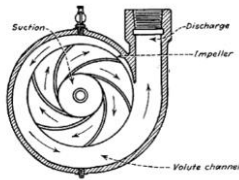

Source: Wikipedia

Centrifugal pumps are a sub-class of dynamic axisymmetric work-absorbing [turbomachinery](#).^[1] Centrifugal pumps are used to transport fluids by the conversion of rotational kinetic energy to the hydrodynamic energy of the fluid flow. The rotational energy typically comes from an engine or electric motor. In the typical case, the fluid enters the pump impeller along or near to the rotating axis and is accelerated by the impeller, flowing radially outward into a diffuser or [volute](#) chamber (casing), from where it exits.

The kinetic energy of the water created by a centrifugal pump could be much higher than the energy created in the drive pipe (1) of a regular hydraulic ram pump.

- The drive pipe changed to a centrifugal pump. (2,4 or more pipes which are connected to the hollow axle)

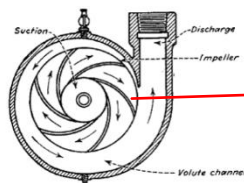
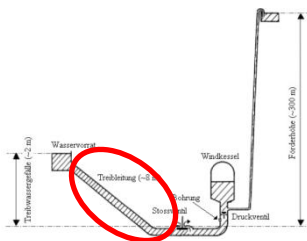

- The valve is exchanged for holes in a stator plate and an opening in the centrifugal “pipes”. By turning the centrifugal pipes, the holes in the stator plate act like valves which open and close the hole in the centrifugal pipe. (A close fit between the centrifugal pipe hole and the stator plate is required).

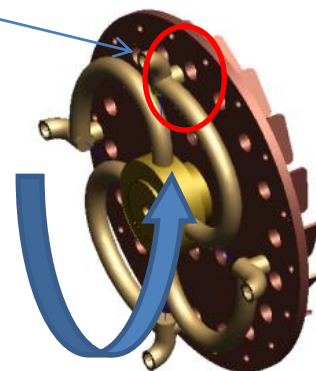
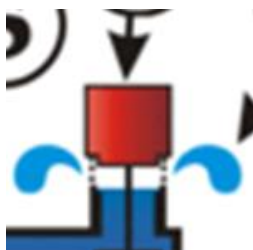

A pressure vessel is mounted to the axle. The ends of the centrifugal pipes are connected to the vessel so that the fluid can flow into the vessel. A check valve is added to the end of the centrifugal pipes. (These check valves can be located inside or outside of the pressure vessel)

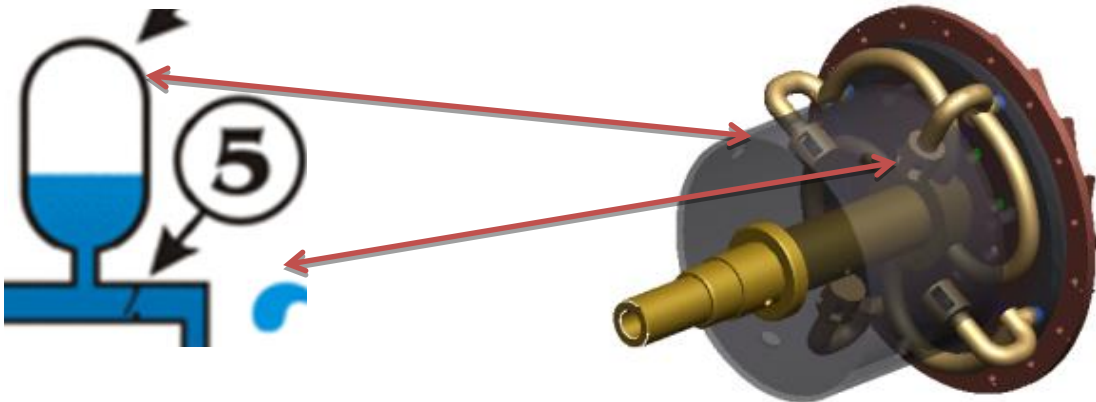

The outlet – delivery pipe is exchanged for some jet, through which the fluid can exit the pressure vessel.

The high pressure fluid which exit through these jets keep the motor running.

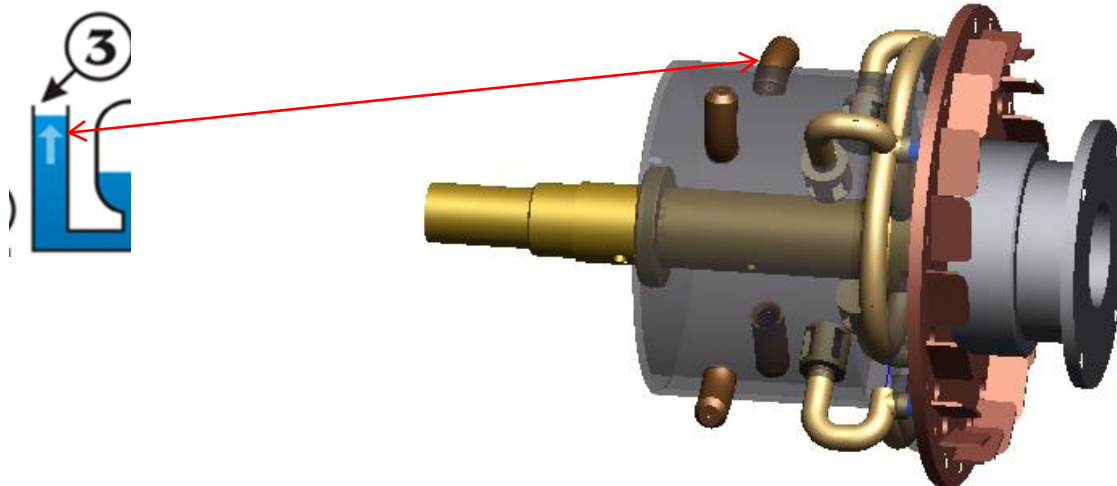

A motor-housing and some discharge-rips for the jets are added to this setup. The main engine than looks about like this:

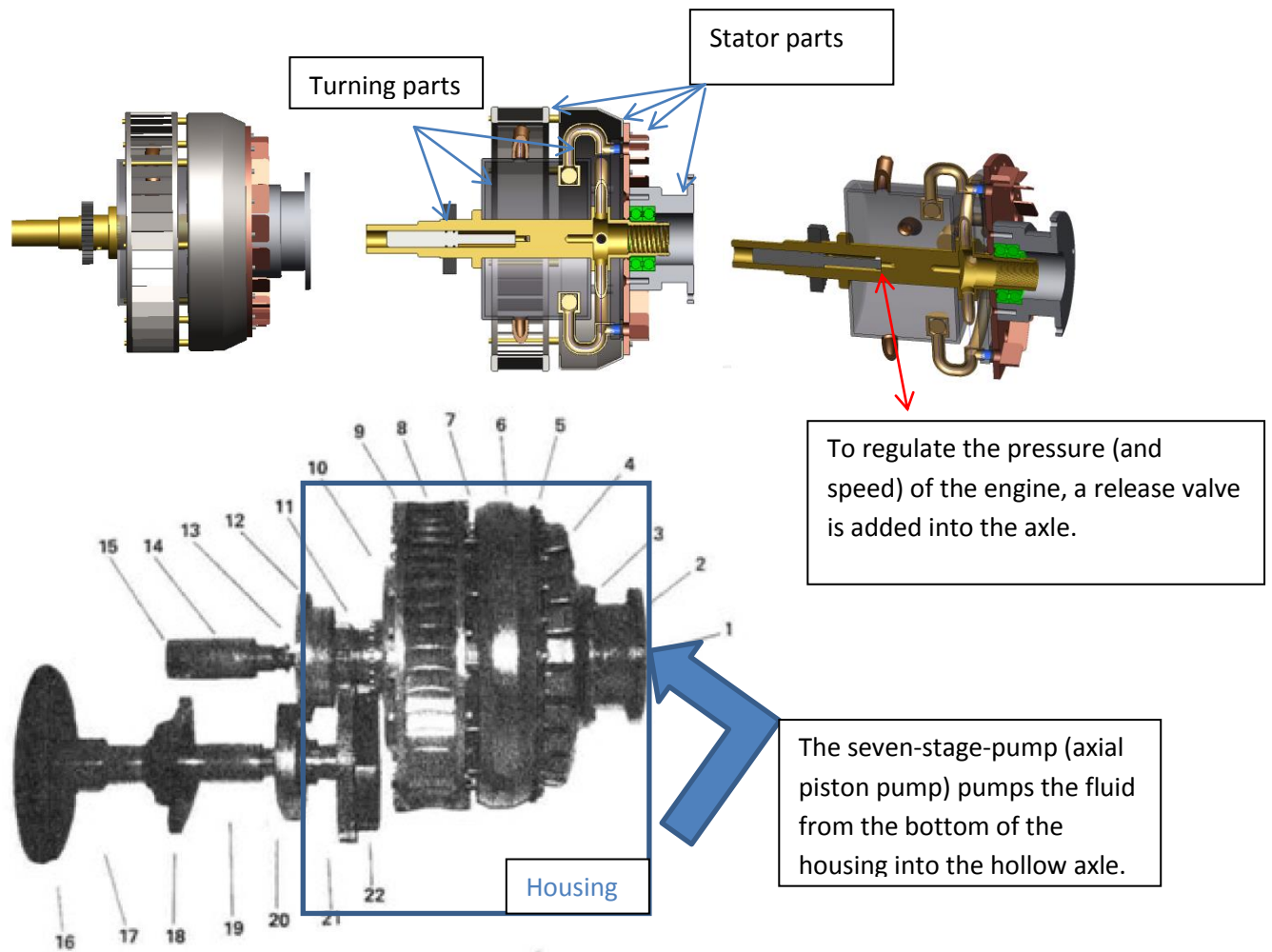

The pump is used to pump the oil from the bottom of the housing into the hollow axle of the engine.

Here some calculations: (all the centrifugal pipes pass the holes in the plate at the same time)

Engine speed: 2000 RPM

Valves (holes in plate): 18 pcs

$2000 \text{ RPM} / 60 \text{ sec} = 33.33 \text{ RPM /sec}$

$33.33 \times 18 = 599.94$ openings and closings of the valve per second

$1 \text{ Second} / 599.94 = \mathbf{0.0016 \text{ Millisecond}}$ for each opening and closing of the valve

Each opening and closing of the valve creates a little "Microburst", which pushes a small amount of fluid into the pressure vessel. Because of the centrifugal force, the fluid inside the pressure vessel will get pushed toward the inside wall of the pressure vessel and the air will stay in the center of the pressure vessel.

In order to regulate the pressure inside the pressure vessel a relieve valve is added in the axle of the engine. The air inside the pressure vessel can escape by opening the relieve valve. This set-up will regulate the continues increasing pressure inside the pressure vessel.

The axle, which includes the pressure vessel and the centrifugal pipes plus the check valves would be the only rotating parts of the engine. After bringing this engine to a speed of about 2000 rpm (with an external E-motor or otherwise), the fluid which is pumped into the hollow axle will then be centrifuged outward through the centrifugal pipes. When the valve hole of the centrifugal pipe passes the holes of the stator plate, an "opening" in the centrifugal pipe is created and the fluid can escape through the hole of the stator plate.

When the centrifugal pipe passes the stator plate hole, the valve is "closed" and a water hammer inside the centrifugal pipe is created. This water hammer will push some fluid, under great pressure created by the water hammer, into the pressure vessel. A check valve at the end of the centrifugal pipe will prevent the fluid inside the pressure vessel to flow back into the centrifugal pipe. Depending on the set-up this happens about 600 times per second.

The high pressure created inside the pressure vessel will force the fluid out of the jets and keep the motor running.

I'm sure that a lot of improvements can be made when this function is being fully understood.

Please spread this theory to everybody in any possible way you know so that this engine can come back to life again and will change our corrupted world to a better place. Let us all work together as one and spread this news.

My wish to everyone is that the basic principle about this engine will not be patented so that this engine has a change to develop. (Most likely a patent application for this engine would be treated as a secret patent anyway)

My God bless you and the development of this engine.